

Model: DRNT512
operating instructions

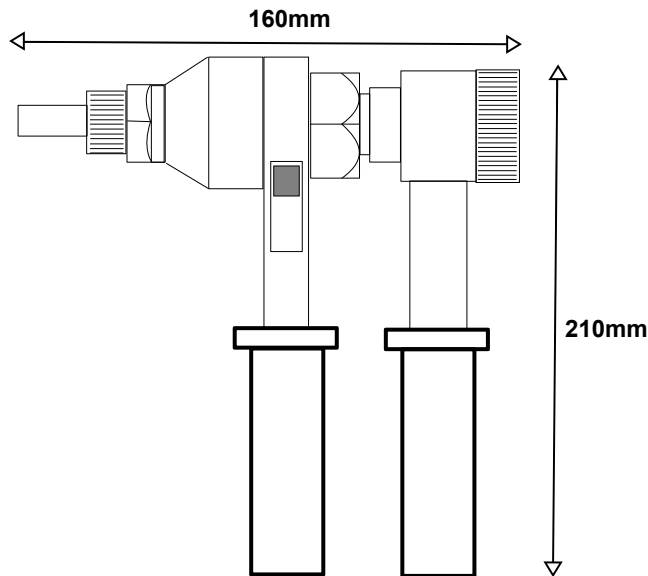

capacity

rivnuts: M5 - M6 - M8 - M10 - M12
rivstuds: M5 - M6 - M8



Unscrew anvil and locknut

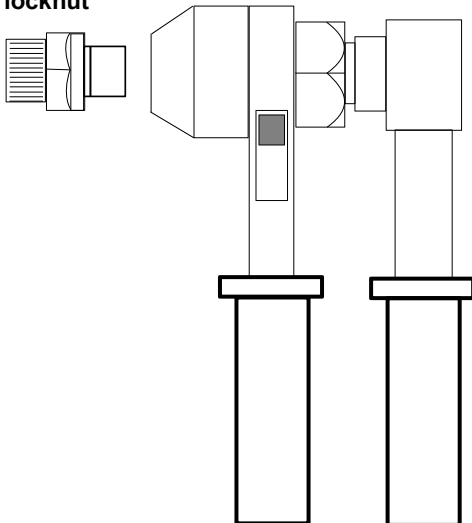

Pull mandrel to remove from tool body.

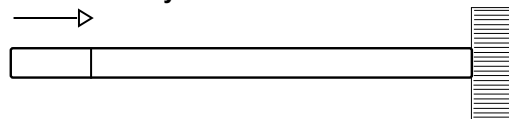

IMPORTANT - WHEN USING M5 AND M6 RIVNUTS, ALWAYS TEST SET RIVNUTS INTO SCRAP MATERIAL. ONLY A SMALL AMOUNT OF FORCE IS REQUIRED TO SET THESE RIVNUTS.



UNNECESSARY OVER TIGHTENING MAY RESULT IN DAMAGE TO THE TOOL MANDREL OR RIVNUT THREADS.

IMPORTANT - MAINTENANCE TIP
APPLY GREASE TO THE LOAD TRANSFER THREAD.
THIS IS DONE BY WINDING THE TOOL APART, CLEANING AND GREASING THE THREAD.
MAINTENANCE TIME APPROX 5 MINUTES.

DRNT512 setting a rivnut or rivstud

